



OPERATOR'S MANUAL

A Division of Snow Joe, LLC

CORDLESS BUG ZAPPER

24V* IONMAX | USB-C + USB-A PORTS

Model 24V-BZ100-LTE

Form No. SJ-24V-BZ100-LTE-880E-M

IMPORTANT!

Safety Instructions

All Operators Must Read These Instructions Before Use

Always follow these safety guidelines. Failure to do so may result in serious bodily injury or death.

General Safety

⚠️ WARNING! This appliance is not intended for use by children or by unassisted, unsupervised persons whose physical, sensory or mental capabilities prevent them from using it safely. Children should be supervised to ensure that they do not play with the appliance.

Before starting up your machine, please check it carefully for any defects. If you find any, do not start up your machine. Instead, contact your authorized Snow Joe® + Sun Joe® dealer or call the Snow Joe® + Sun Joe® customer service center at 1-866-SNOWJOE (1-866-766-9563).

⚠️ WARNING! When using the power tool, basic safety precautions should always be followed to reduce the risk of fire, electric shock, and personal injury. These include

- Read all the instructions before using the tool.
- Do not look into the light, or expose the light to eyes. Eyes may be damaged.
- To reduce the risk of injury, children must be supervised when using the tool around them.
- To reduce the risk of electrical shock, do not put the bug zapper or charger in water or other liquid. Do not place or store them where they can fall or be pulled into a tub or sink.
- Recharge only with the charger specified by the manufacturer. A charger that is suitable for one type of battery pack may create a risk of fire when used with another battery pack.
- Use tool only with specifically designated battery packs. Use of any other battery packs may create a risk of injury or fire.
- Remove battery pack from cordless bug zapper before performing any routine maintenance or cleaning.
- Do not disassemble the bug zapper.
- Do not place bug zapper or battery pack near fire or heat. They may explode. Do not incinerate the battery, even if it is severely damaged or completely worn out. The battery may explode in fire.

- Do not operate bug zapper or charger near flammable liquids or in gaseous or explosive atmospheres. Internal sparks may ignite fumes.
- Do not store in locations where the temperature is fewer than 50°F or more than 100°F. Do not store in outside sheds in direct sunlight or in vehicles.
- Do not permit children to use bug zapper.
- Keep bug zapper dry, clean, and free from oil and grease. Always use a clean cloth when cleaning. Never use brake fluids, gasoline, petroleum-based products, or any strong solvent to clean the bug zapper.
- Do not overreach while holding the bug zapper. Keep proper footing and balance at all times. Proper footing and balance enable better control of the bug zapper in unexpected situations. Do not use on a ladder or unstable support.

⚠️ WARNING! Do not use this appliance without reading this instruction manual.

Bug Zapper Use + Care

- Disconnect the product from the power supply when not in use, before servicing, when changing bulbs, cleaning, and similar actions.
- Do not insert foreign objects into this product.
- Store products indoors when not in use – out of reach of children.
- Do not clean this product with a water spray or similar method.
- Do not permit children to use this product. It is not a toy.
- If wrapped or in contact with fabrics, the product's light produces sufficient heat to melt some fabrics.
- This product is intended for household use only.

Safety Rules for Bug Zapper

- Always remove battery pack before storing the device.
- Under extreme usage or temperature conditions, battery leakage may occur. If liquid comes in contact with your skin, wash immediately with soap and water. If liquid gets in your eyes, flush them with clean water for at least 10 minutes, then seek immediate medical attention.

***DISCLAIMER:** Initial no-load voltage, when fully charged, peaks at 24V; nominal voltage under typical load is 21.6V.

- Batteries can explode in the presence of a source of ignition, such as a pilot light. To reduce the risk of serious personal injury, never use any cordless product in the presence of open flame. An exploded battery can propel debris and chemicals. If exposed, flush with water immediately.
- Do not crush, drop or damage battery pack. Do not use a battery pack or charger that has been dropped or received a sharp blow. A damaged battery is subject to explosion. Properly dispose of a dropped or damaged battery immediately. Failure to heed this warning can result in serious personal injury.
- Save these instructions. Refer to them frequently and use them to instruct others who may use this tool. If you loan someone this tool, loan them these instructions also.

Battery & Charger Safety Instructions

We pay a great deal of attention to the design of every battery pack to ensure that we supply you with batteries that are safe, durable and have a high energy density. The battery cells have a wide range of safety devices. Each individual cell is initially formatted and its electrical characteristic curves are recorded. This data is then used exclusively to assemble the best possible battery packs.

Despite all the safety precautions, caution must always be exercised when handling batteries. The following points must be obeyed at all times to ensure safe use. Safe use can only be guaranteed if undamaged cells are used. Incorrect handling of the battery packs can cause cell damage.

IMPORTANT! Analyses confirm that incorrect use and poor care of high-performance batteries are the main factors responsible for product damage and/or personal injury.

⚠️ WARNING! To reduce the risk of injury, use only official 24V IONMAX designated chargers and battery packs. The use of other batteries or chargers poses a risk of fire, personal injury and damage.

⚠️ WARNING! Do not use a battery pack or product that has been damaged or modified. Damaged or modified batteries may exhibit unpredictable behavior resulting in fire, explosion or risk of injury.

Do not modify or attempt to repair the product or the battery pack except as indicated in the instructions for use and care. Do not wire a battery pack to a power supply or car cigarette lighter, as such misuse will permanently disable or damage the battery pack.

Have your battery pack serviced by a qualified repair person using only identical replacement parts. This will ensure that the safety of the battery pack is maintained.





⚠️ WARNING! To reduce the risk of electric shock, always unplug the charger before performing any cleaning or maintenance. Do not allow water to flow into the charger. Use a Ground Fault Circuit Interrupter (GFCI) to reduce shock hazards.

- **Remove battery** – Remove the battery pack from the tool when not in use, before servicing, or before performing any other maintenance task. Never leave the tool unattended while switched on. In the event of an accident or breakdown, switch off the tool immediately.
- **Avoid dangerous environments** – Do not charge the battery packs in rain, snow or in damp or wet locations. Do not use the battery pack or charger in the presence of explosive atmospheres (gaseous fumes, dust or flammable materials) because sparks may be generated when inserting or removing the battery packs, which could lead to a fire.
- **NOTE:** The safe temperature range for the batteries are 41°F (5°C) to 105°F (40.5°C). Do not charge the batteries outside in freezing weather; charge them at room temperature.
- **Charge in a well-ventilated area** – Do not block the charger vents. Keep them clear to allow for proper ventilation. Do not allow smoking or open flames near a charging battery pack. Vented gases may explode.
- **Maintain charger cord** – When unplugging the charger, pull the plug, not the cord from the receptacle to reduce the risk of damage to the power cord. Never carry the charger by its cord. Keep the cord away from heat, oil and sharp edges. Make sure the cord will not be stepped on, tripped over or subjected to damage or stress when the charger is in use. Do not use a charger with a damaged cord or plug. Replace a damaged charger immediately.
- **Do not use an extension cord unless it is absolutely necessary** – Using the wrong, damaged or improperly wired extension cord poses a risk of fire and electric shock. If an extension cord must be used, plug the charger into a properly wired 16 gauge or larger extension cord with the female plug matching the male plug on the charger. Make sure that the extension cord is in good electrical condition.
- **Do not expose the machine or battery packs to fire** – Exposure to fire or temperatures above 265°F (130°C) may cause the battery packs to explode, causing personal injury or damage. Toxic fumes and materials are created when battery packs are ignited.
- **Do not crush, drop or damage battery packs** – Do not use the battery packs or charger if they have sustained a sharp blow, been dropped from a height of more than 3 feet (1 meter), run over or have been damaged in any way. Even if the housing of a battery pack appears to be undamaged, the battery cells inside the battery may have suffered serious damage. In such instances, please read the waste disposal information for proper battery disposal.

- **Do not disassemble** – Incorrect reassembly may pose a serious risk of electric shock, fire or exposure to toxic battery chemicals. If the battery or charger is damaged, contact an authorized Snow Joe® + Sun Joe® dealer or call the Snow Joe® + Sun Joe® customer service center at 1-866-SNOWJOE (1-866-766-9563) for assistance.
- **Battery chemicals cause serious burns** – Never let a damaged battery pack contact the skin, eyes or mouth. If damaged, battery chemicals will react violently with air. Use rubber or neoprene gloves to safely dispose of the battery. If skin is exposed to battery chemicals, wash the affected area with soap and water. If eyes are exposed to battery chemicals, immediately flush with water for 20 minutes and seek medical attention. Remove and dispose of contaminated clothing.
- **Risk of short circuit** – A battery pack will short circuit if a metal object makes a connection between the positive and negative contacts on the battery pack. Do not place a battery pack near anything that may cause a short circuit, such as paperclips, coins, keys, screws, nails and other metallic objects. A short-circuited battery pack poses a risk of fire and severe personal injury.
- **Store your battery packs and charger in a cool, dry place** – Ideally, store the battery packs at 59°F (15°C) and charged to at least 40%. Do not store the battery packs or charger where temperatures may exceed 105°F (40.5°C), such as in direct sunlight or inside a vehicle, or where temperatures may drop below 41°F (5°C).
- **NOTE:** Prevent the battery packs from freezing. Battery packs that were stored below 32°F (0°C) for more than 60 minutes must be discarded.
- **Charge before use** – The battery pack supplied with your machine is only partially charged. The battery pack must be fully charged before using the bug zapper for the first time.
- **Battery Aging** – Lithium-ion batteries are subject to a natural aging process. A battery pack must be replaced at the latest when its capacity falls to just 80% of its capacity when new. Weakened cells in an aged battery pack are no longer capable of meeting the high power requirements needed for the proper operation of your machine, and therefore pose a safety risk.
- **Do not exhaustively discharge battery packs** – A complete discharge will damage the battery cells. The most common cause of exhaustive discharge is lengthy storage. Stop working as soon as the performance of a battery falls noticeably or the electronic protection system triggers. For optimum battery performance, charge the battery packs frequently. Place the battery packs in storage only after they have been fully charged.
- **Do not overload battery packs** – Protect the bug zapper and battery from overloading. Overloads will quickly result in overheating and cell damage inside the battery housing even if it is not apparent externally. For safety reasons, the integrated protective cutoff will activate to switch off the equipment. After regular use, allow the battery packs to cool to room temperature before recharging them.
- **IMPORTANT!** Do not attempt to turn on the machine if the protective cutoff has been activated. This may damage the battery packs.
- **Outlet voltage** – Please check the data marked on the rating label of the battery charger. Be sure that the voltage of the power supply matches that marked on the rating label. Never connect it to a different mains voltage.
- **Charger use** – Do not use the battery charger to charge other types of battery packs or tools.
- **Do not overcharge battery packs** – Do not exceed the maximum charging times. Frequently overcharging the battery packs will result in cell damage. Do not leave battery connected to the charger for days on end.
- **Battery pack abnormalities** – Do not use batteries that have suffered swelling or deformation or those that exhibit other atypical symptoms (gassing, hissing, cracking, etc.).
- **Electrostatic discharge** – When handling batteries, be wary of electrostatic charge. Electrostatic discharges can damage the electronic protection system and the battery cells. To avoid electrostatic discharges, never touch the battery terminals.

Safety Symbols

The following table depicts and describes safety symbols that may appear on this product. Read, understand, and follow all instructions on the product before attempting to assemble and operate.

Symbols	Descriptions	Symbols	Descriptions
	READ THE OPERATOR'S MANUAL(S) – Read, understand, and follow all instructions in the user manual(s) before attempting to assemble and operate.		SAFETY ALERT – Indicates a precaution, a warning, or a danger.
	Do not expose to rain or use in damp locations.		To reduce the risk of electrocution or electric shock, keep away from water.
V	Voltage		Type or a characteristic of current.

Know Your 24V Max* Cordless Bug Zapper

Read the owner's manual and safety instructions carefully before operating the bug zapper. Compare the illustration below to the product in order to become familiar with the location of the various controls and adjustments. Save this manual for future reference.

1. Handle
2. Hanging hook
3. LED worklight
4. Protective panel
5. Collection tray
6. Touch screen display
7. Battery compartment
8. USB-C port
9. USB-A port
10. Latch
11. Cleaning brush
12. 24V* IONMAX lithium-ion battery (24VBAT-LTE) featuring exclusive EcoSharp® technology
13. Charge socket
14. Push lock button (2)
15. Push button for battery indicator
16. Battery indicator
17. 24V* IONMAX lithium-ion charger (XZ2600-0450)
18. Charger plug

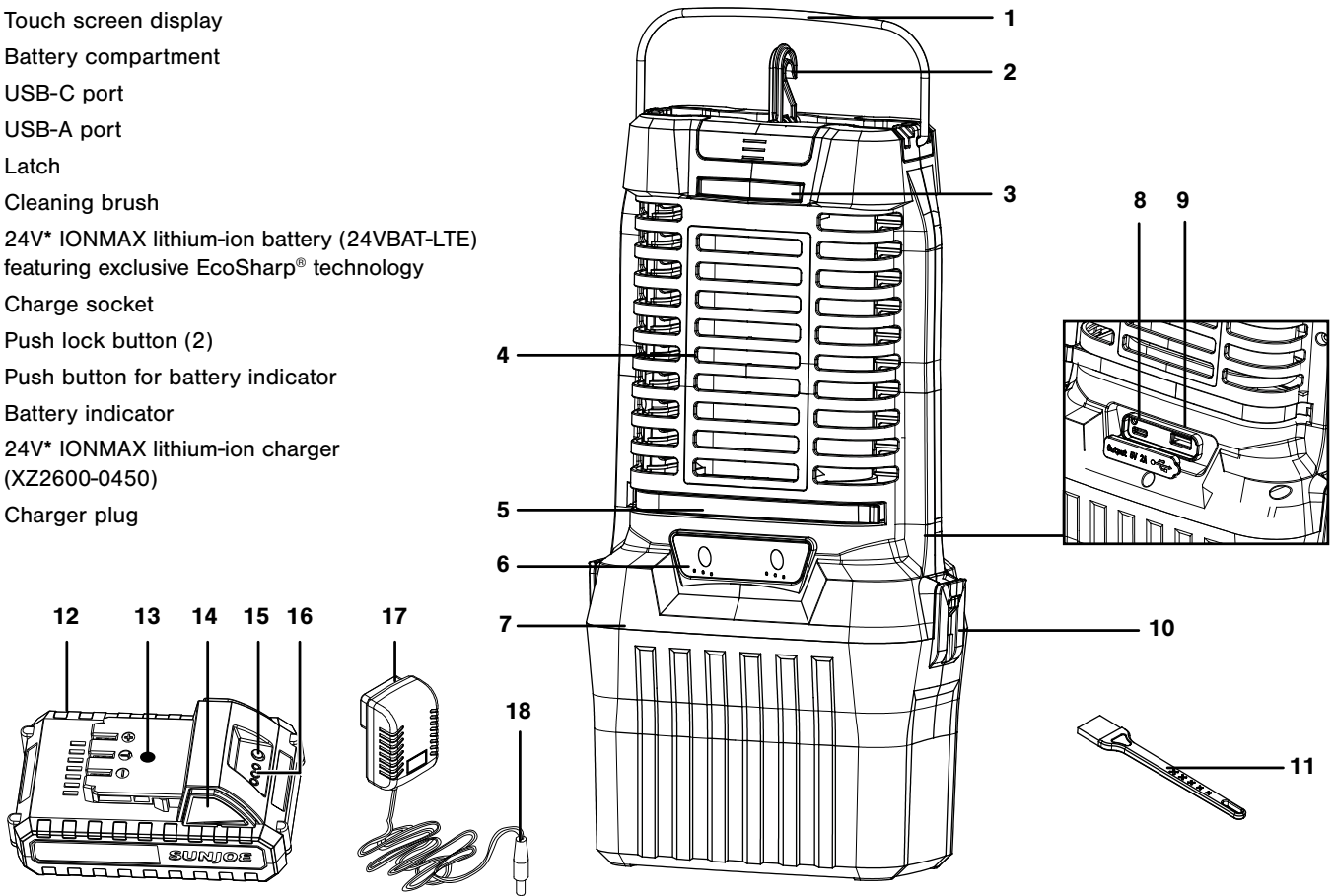

Technical Data

Electric Grid.....	2500 V D.C.	Charger Output	26V DC 450 mA
UV Black Light	10 W	Charge Time Max	5 hours
Battery Voltage Max*	24 V D.C.	LED worklight lumens	33 (low), 45 (medium), 65 (high)
Battery Capacity	2.0 Ah	Charging Ports	USB-A + USB-C (5V 2A)
Charger Input	100 – 240V AC 50/60 Hz 0.4 A	Net weight	2.3 lbs (1.04 kg)

***DISCLAIMER:** Initial no-load voltage, when fully charged, peaks at 24V; nominal voltage under typical load is 21.6V.

Unpacking

Carton Contents

- Bug zapper
- Cleaning brush
- Battery compartment cover
- 24V* IONMAX lithium-ion battery
- 24V* IONMAX lithium-ion battery charger
- Manual with registration card

1. Carefully remove the cordless bug zapper and check to see that all of the above items are supplied.
2. Inspect the product carefully to make sure no breakage or damage occurred during shipping. If you find damaged or missing parts, DO NOT return the unit to the store. Instead, please call the Snow Joe® + Sun Joe® customer service center at 1-866-SNOWJOE (1-866-766-9563).

NOTE: Do not discard the shipping carton and packaging materials until you are ready to use your new cordless bug zapper. The packaging is made of recyclable materials.

Properly dispose of these materials in accordance with local regulations.





IMPORTANT! The equipment and packaging materials are not toys. Do not let children play with plastic bags, foils or small parts. These items can be swallowed and pose a suffocation risk!

Battery Pack Operation

The equipment is powered by a lithium-ion battery. The battery pack is completely sealed and maintenance free.

Battery Charge Level Indicator

The battery pack is equipped with a push button for checking the charge level. Simply press the push button to read off the battery charge level from the LEDs of the battery indicator:

Lights	Light Indicators
	Charge level button
	The battery is at 30% capacity
	The battery is at 60% capacity
	The battery is fully charged

NOTE: If the battery indicator button does not appear to be working, charge the battery.

NOTE: Immediately after using the battery pack, the battery indicator button may display a lower charge than it will if checked a few minutes later. The battery cells “recover” some of their charge after resting.

Charger Operation

⚠️WARNING! Only charge Sun Joe® 24V lithium-ion battery pack with compatible Sun Joe® 24V lithium-ion chargers. Other types of chargers may cause personal injury and damage.

To reduce the risk of electric shock, do not allow water to enter into the charger.

Charging the Battery

1. Push the push lock buttons on either side of the battery pack to pull it out from the battery compartment (Fig. 1)

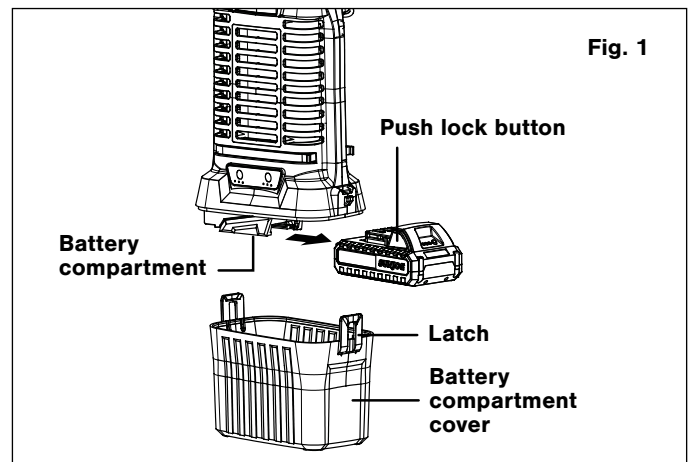

2. Check that the mains voltage is the same as that marked on the rating plate of the battery charger. Then plug the charger into an appropriate AC power outlet. Connect the charger plug into the charging socket of the battery to start charging (Fig. 2).

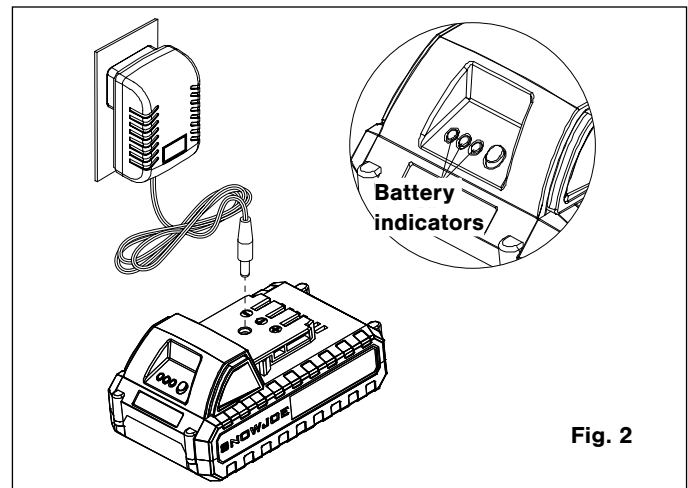

3. The battery will take approximately 5 hours to charge. The battery indicator LEDs will cycle on one by one during the charging process. Unplug the charger immediately when all 3 LEDs are illuminated.

CAUTION! FIRE HAZARD. When disconnecting the charger from the battery, be sure to unplug the charger from the outlet first, then disconnect the battery from the charger.

WARNING! This charger does not automatically turn off when the battery is fully charged. Please take care not to leave the battery plugged into the charger. Switch off or unplug the charger at the mains when charging is complete.

4. Timely recharging of the battery will help prolong the battery's life. Recharge the battery pack when you notice a drop in the equipment's power.

IMPORTANT! Never allow the battery pack to become fully discharged as this will cause irreversible damage to the battery.

Assembly

WARNING! Do not use this product if it is not completely assembled or if any parts appear to be missing or damaged. Use of a product that is not properly and completely assembled or with damaged or missing parts could result in serious personal injury.

WARNING! Do not attempt to modify this product or create accessories or attachments not recommended for use with this product. Any such alteration or modification is misuse and could result in a hazardous condition leading to possible serious personal injury.

If any parts are damaged or missing, please call the Snow Joe® + Sun Joe® customer service center at 1-866-SNOWJOE (1-866-766-9563) for assistance.

Operation

WARNING! Do not allow familiarity with tools to make you careless. Remember that a careless fraction of a second is sufficient to inflict serious injury.

WARNING! Do not use any attachments or accessories not recommended by the manufacturer of this tool. The use of attachments or accessories not recommended can result in serious personal injury.

WARNING! Keep the bug zapper away from combustible materials. If wrapped or in contact with fabrics, the light may produce sufficient heat to melt some fabrics.

WARNING! To reduce the risk of fire, remove insects and empty bug tray frequently.

WARNING! Do not insert foreign objects into this product. Doing so could damage the product and/or result in an electric shock.

WARNING! Battery tools are always in operating condition. Therefore, unit should always be OFF with the battery pack removed when not in use. Failure to follow these instructions could result in serious personal injury.

WARNING! Always remove battery pack from your product when you are assembling parts, making adjustments, cleaning, or when not in use. Removing battery pack will prevent accidental starting that could cause serious personal injury.

1. Remove the battery compartment cover, then insert the battery pack into the battery compartment until the push lock buttons click into place (Fig. 3).
2. Close the battery compartment cover. Make sure the latches on each side of the cover snap into place and the battery pack is secured before beginning operation.

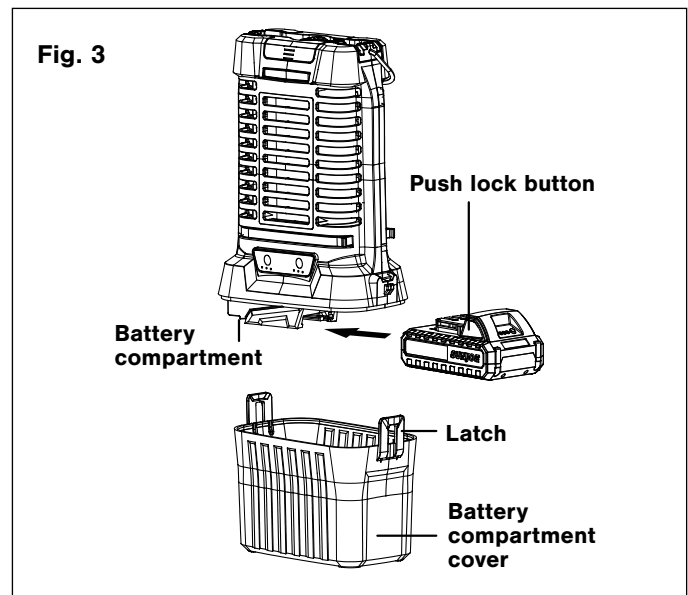

WARNING! Battery products are always in operating condition. Therefore, remove the battery pack when the product is not in use or when carrying at your side.

UV Light/LED

The bug zapper has two settings: UV Light and LED (Fig. 4).

- UV Light: touch the UV light switch to cycle between 2 hours, 4 hours, 6 hours, and off as indicated by the LEDs below the UV light switch.
- LED: gently touch the LED switch to switch on low light; touch twice: medium light; touch three times: high light; touch four times: switch off the LED

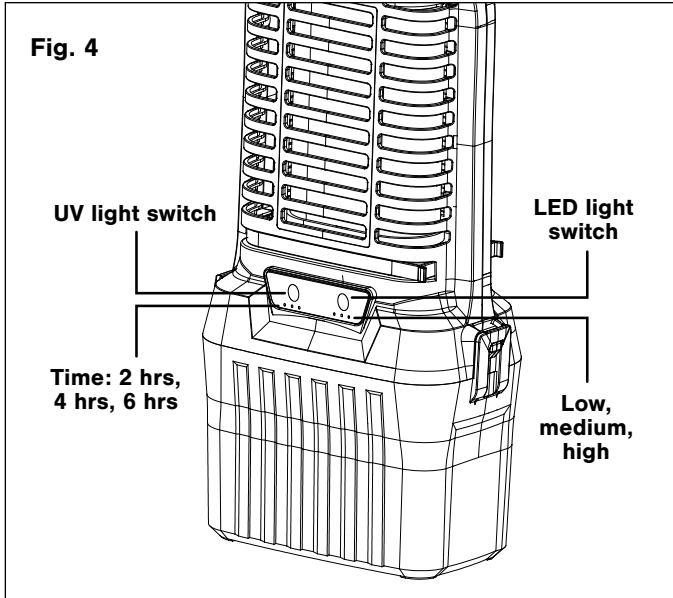

NOTE: Do not attach anything other than the battery pack to the bug zapper when it is hanging from the hook. Do not stand under the hanging bug zapper to prevent hazard from falling.

2. Be careful not to hang the bug zapper in a position that prevents normal operation of the bug zapper.
3. When not hanging, pull out the handle and use it as a night light (Fig. 6).

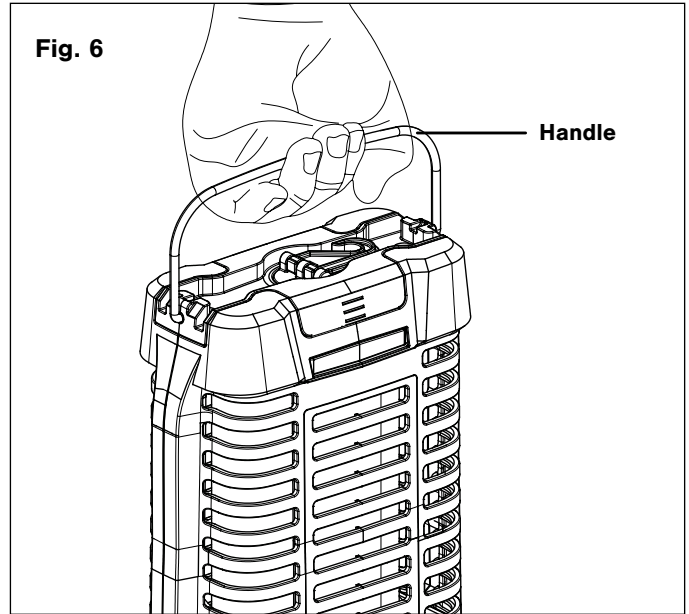

OPERATING TIPS

- For best results, hang the product 6 to 7 ft. above the ground.
 - Dead insects and debris will accumulate in the bug tray. Remove insects and empty bug tray frequently. To clean the tray, open the tray from two sides and dump the waste into a trash receptacle. If necessary, use a brush to clean the inside of the tray.
 - **NOTE:** Be sure to wash your hands thoroughly with soap and water after handling the bug tray.
 - Periodically, remove the battery pack and use a soft brush or forced air to remove dead insects or debris from the product.
 - Remove the battery pack and store product indoors during severe weather. This product can withstand moderate rainfall, but it should not be left outdoors during severe weather events.
1. Lift the hanging hook and rotate to the desired position for hanging (Fig. 5).

Using the USB-A + USB-C Ports

Both USB charging ports provide 5V DC charging power for your mobile phone, MP3 player and other USB devices, and up to 2 amps total.

CAUTION! Attempting to charge devices rated more than 2 amps, such as a tablet, could damage the USB charging ports and/or the devices.

1. Open the rubber USB ports cover protector (Fig. 7).

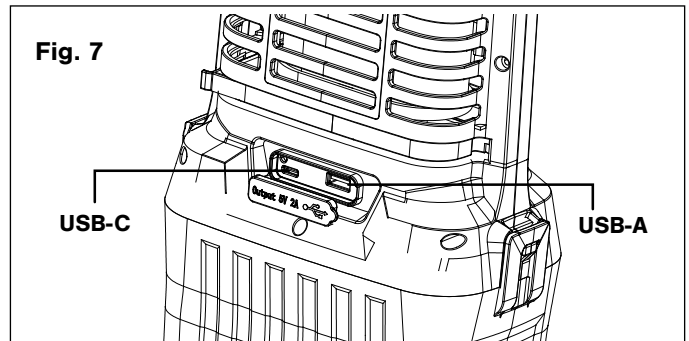
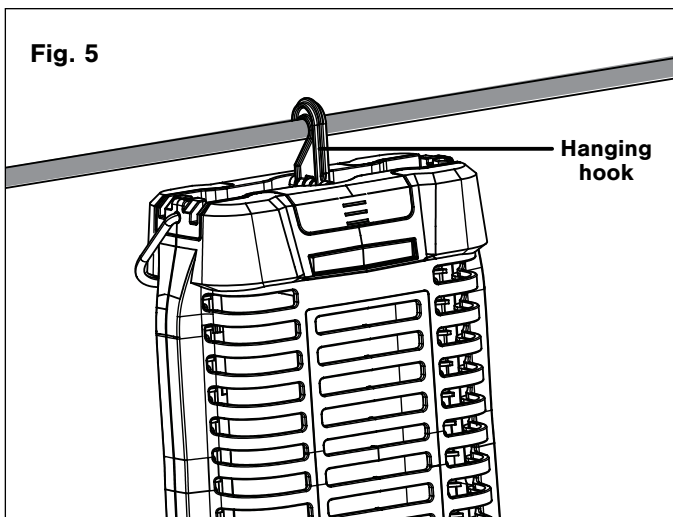

2. Connect one end of the USB cable (not included) to your USB device.

3. Connect the other end of the USB cable (not included) to the USB charging port. Then press the UV light or LED light switch to start charging the device (Fig. 8).

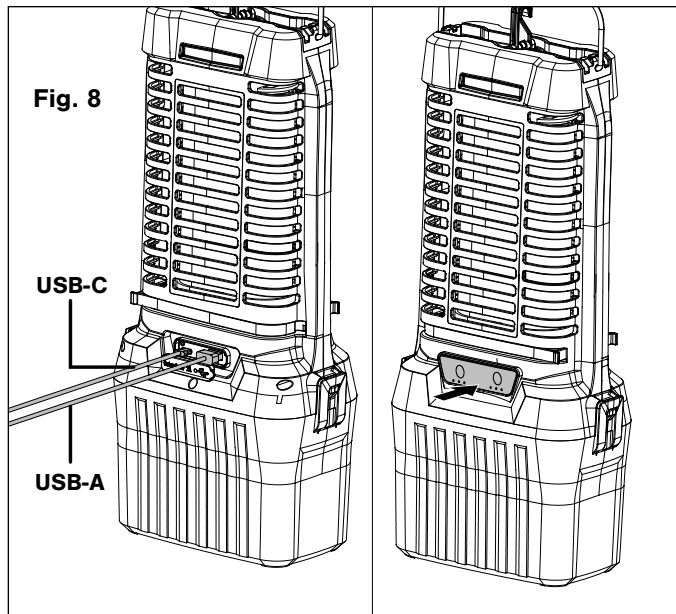

4. After charging, remove the USB cable, then put the rubber USB ports cover protector back into place.

Cleaning the Collection Tray

1. Open the bug collection tray to 60°, and then clean the tray with the cleaning brush. Avoid touching insects by hand.
2. Close the collection tray back into the housing (Fig. 9).

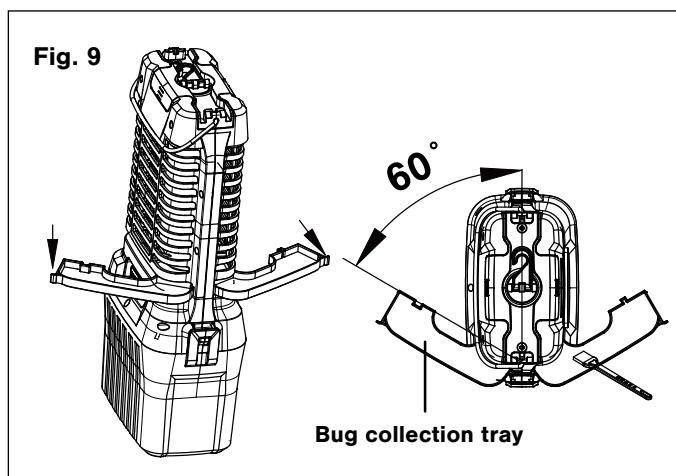

Maintenance

Please contact an authorized Snow Joe® + Sun Joe® dealer or call the Snow Joe® + Sun Joe® customer service center at 1-866-SNOWJOE (1-866-766-9563) for all maintenance operations not detailed in this manual. Any operation performed in an unauthorized service center or by unqualified personnel will completely invalidate the warranty.

⚠ WARNING! To avoid serious personal injury, always remove the battery pack from the product when cleaning or performing any maintenance.

⚠ WARNING! When servicing, use only identical replacement parts. Use of any other parts could create a hazard or cause product damage.

NOTE: Periodically inspect the entire product for damaged, missing, or loose parts such as screws, nuts, bolts, caps, etc. Tighten securely all fasteners and caps and do not operate this product until all missing or damaged parts are replaced. Please contact customer service or a qualified service center for assistance.

GENERAL MAINTENANCE

Avoid using solvents when cleaning plastic parts. Most plastics are susceptible to damage from various types of commercial solvents and may be damaged by their use. Use clean cloths to remove dirt, dust, oil, grease, etc.

⚠ WARNING! Do not at any time let brake fluids, gasoline, penetrating oils, etc., come in contact with plastic parts. Chemicals can damage, weaken, or destroy plastic, which may result in serious personal injury.

BULB REPLACEMENT

1. Unscrew the two M5 screws from the bug zapper top and remove the upper cover of bug zapper.
2. Take out the old UV light upward; insert the new UV light downward.
3. Reassemble the upper cover with M5 screws (Fig. 10).

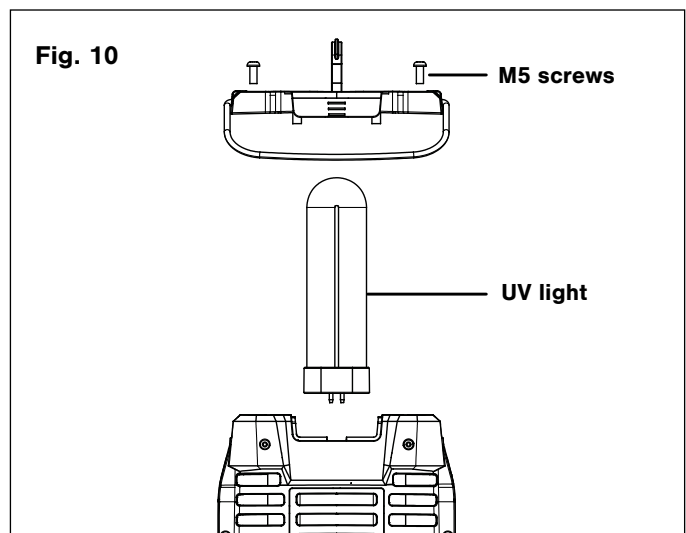

STORING THE BUG ZAPPER

Store indoors in a dry, locked-up place, out of the reach of children, with the battery pack removed. Keep away from corrosive agents such as garden chemicals and deicing salts.

Battery Caution + Disposal

Always dispose of your battery pack according to federal, state, and local regulations. Contact a recycling agency in your area for recycling locations.

⚠ CAUTION! Even discharged battery packs contain some energy. Before disposing, use electrical tape to cover the terminals to prevent the battery pack from shorting, which could cause a fire or explosion.

⚠ WARNING! To reduce the risk of injury or explosion, never burn or incinerate a battery pack even if it is damaged, dead, or completely discharged. When burned, toxic fumes and materials are emitted into the surrounding environment.

- Batteries vary according to device. Consult your manual for specific information.
- Install only new batteries of the same type in your product (where applicable).
- Failure to insert batteries in the correct polarity, as indicated in the battery compartment or manual, may shorten the life of the batteries or cause batteries to leak.
- Do not mix old and new batteries.
- Do not mix Alkaline, Standard (Carbon-Zinc), or Rechargeable (Nickel Cadmium, Nickel Metal Hydride, or Lithium-Ion) batteries.
- Do not dispose of batteries in fire.
- Batteries should be recycled or disposed of as per state and local guidelines.

Recycling + Disposal

The product comes in a package that protects it against damage during shipping. Keep the package until you are sure that all parts have been delivered and the product is functioning properly. Recycle the package afterwards or keep it for long-term storage.



WEEE symbol. Waste electrical products should not be disposed of with household waste. Please recycle where facilities exist. Check with your local authority or local store for recycling regulations.

Service + Support

If your Sun Joe® 24V-BZ100-LTE cordless bug zapper requires service or maintenance, please call 1-866-SNOWJOE (1-866-766-9563) for assistance.

Model + Serial Numbers

When contacting the company, reordering parts, or arranging service from an authorized dealer, you will need to provide the model and serial numbers, which can be found on the decal located on the housing of the unit. Copy these numbers into the space provided below.

Record the following numbers from the housing or handle of your new product:	
Model #:	
2 4 V - B Z 1 0 0 - L T E	
Serial #:	

XZ2600-0450

Federal Communications Commission (FCC)

⚠ WARNING! Any changes or modifications to this unit not expressly approved by the party responsible for compliance could void the user's authority to operate the equipment.

This device complies with part 15 of the FCC rules. Operation is subject to the following two conditions: (1) this device may not cause harmful interference, and (2) this device must accept any interference received, including interference that may cause undesired operation.

Class B Device:

NOTE: This equipment has been tested and found to comply with the limits for a Class B digital device, pursuant to part 15 of the FCC Rules.

These limits are designed to provide reasonable protection against harmful interference in a residential installation.

This equipment generates, uses and can radiate radio frequency energy and, if not installed and used in accordance with the instructions, may cause harmful interference to radio communications.



However, there is no guarantee that interference will not occur in a particular installation.

If this equipment does cause harmful interference to radio or television reception, which can be determined by turning the equipment off and on, the user is encouraged to try to correct the interference by one or more of the following measures:

- Reorient or relocate the receiving antenna.
- Increase the separation between the equipment and receiver.
- Connect the equipment to an outlet on a circuit different than the one the receiver is connected to.
- Consult the dealer or an experienced radio/TV technician for help

Optional Accessories

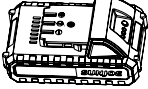
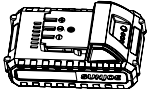
⚠ WARNING! Only use authorized Snow Joe® + Sun Joe® replacement parts and accessories. NEVER use replacement parts or accessories that are not intended for use with this bug zapper. Contact Snow Joe® + Sun Joe® if you are unsure whether it is safe to use a particular replacement part or accessory with your bug zapper. The use of any other attachment or accessory can be dangerous and could cause injury or mechanical damage.

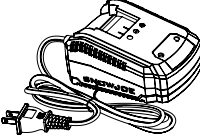
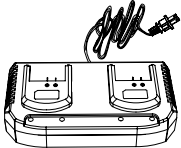
Accessories	Item	Model
	24V* IONMAX 2.0 Ah Lithium-Ion Battery	24VBAT-LTE
	24V* IONMAX 2.5 Ah Lithium-Ion Battery	24VBAT-LT
	24V* IONMAX 4.0 Ah Lithium-Ion Battery	24VBAT
	24V* IONMAX 5.0 Ah Lithium-Ion Battery	24VBAT-XR
	24V* IONMAX Lithium-Ion Battery Quick Charger	24VCHRG-QC
	24V* IONMAX Lithium-Ion Battery Dual Port Charger	24VCHRG-DPC

Visit sunjoe.com for more options

NOTE: Accessories are subject to change without any obligation on the part of Snow Joe® + Sun Joe®. Accessories can be ordered online at sunjoe.com or via phone by contacting the Snow Joe® + Sun Joe® customer service center at 1-866-SNOWJOE (1-866-766-9563).



SNOW JOE® + SUN JOE® CUSTOMER PROMISE

ABOVE ALL ELSE, Snow Joe, LLC (“Snow Joe”) is dedicated to you, our customer. We strive to make your experience as pleasant as possible. Unfortunately, there are times when a Snow Joe®, Sun Joe®, Aqua Joe®, or Auto Joe® product (“Product”) does not work or breaks under normal operating conditions. We think it’s important that you know what you can expect from us. That’s why we have a Limited Warranty (“Warranty”) for our Products.

OUR WARRANTY:

Snow Joe warrants new, genuine, powered and non-powered Products to be free from defects in material or workmanship when used for ordinary household use for a period of two years from the date of delivery of the Product to the original, end-user purchaser when purchased from Snow Joe or from one of Snow Joe’s authorized sellers with proof of purchase. Because Snow Joe is unable to control the quality of its Products sold by unauthorized sellers, unless otherwise prohibited by law, this Warranty does not cover Products purchased from unauthorized sellers. If your Product does not work or there’s an issue with a specific part that is covered by the terms of this Warranty, Snow Joe will elect to either (1) send you a free replacement part, (2) replace the Product with a new or comparable product at no charge, or (3) repair the Product. How cool is that!

This Warranty gives you specific legal rights, and you may also have other rights which vary from State to State.

PRODUCT REGISTRATION:

Snow Joe strongly encourages you to register your Product. You can register online at snowjoe.com/register, or by printing and mailing in a registration card available online from our website, or by calling our Customer Service Department at **1-866-SNOWJOE (1-866-766-9563)**, or by e-mailing us at help@snowjoe.com. Failure to register your Product will not diminish your warranty rights. However, registering your Product will allow Snow Joe to better serve you with any of your customer service needs.

WHO CAN SEEK LIMITED WARRANTY COVERAGE:

This Warranty is extended by Snow Joe to the original purchaser and original owner of the Product.

WHAT IS NOT COVERED?

This Warranty does not apply if the Product has been used commercially or for non-household or rental applications. This Warranty also does not apply if the Product was purchased from an unauthorized seller. This Warranty also does not cover cosmetic changes that do not affect performance. Wearing parts like belts, augers, chains and tines are not covered under this Warranty, and can be purchased at snowjoe.com/support or by calling **1-866-SNOWJOE (1-866-766-9563)**.



Keep your warranty intact. Only use **CERTIFIED AUTHENTIC** Snow Joe®, Sun Joe®, Aqua Joe® + Auto Joe® replacement parts + accessories. Use of any other parts + accessories will void the warranty. Genuine parts + accessories can be found and purchased online at snowjoe.com/support by entering the model number of your product.